



BUILDING A HOUSE USING DURALITE BOARD



Suite E-08-08, Plaza Mont' Kiara, No. 2 Jalan 1/70C, Mont' Kiara
50480 Kuala Lumpur, Malaysia
Tel: (03) 6023 5085 Fax: (03) 6023 5086

1. AFTER CLEARING AND LEVELING OF THE PLATFORM, THE POSITIONS OF THE EXTERNAL AND INTERNAL WALLS ARE SET-OUT

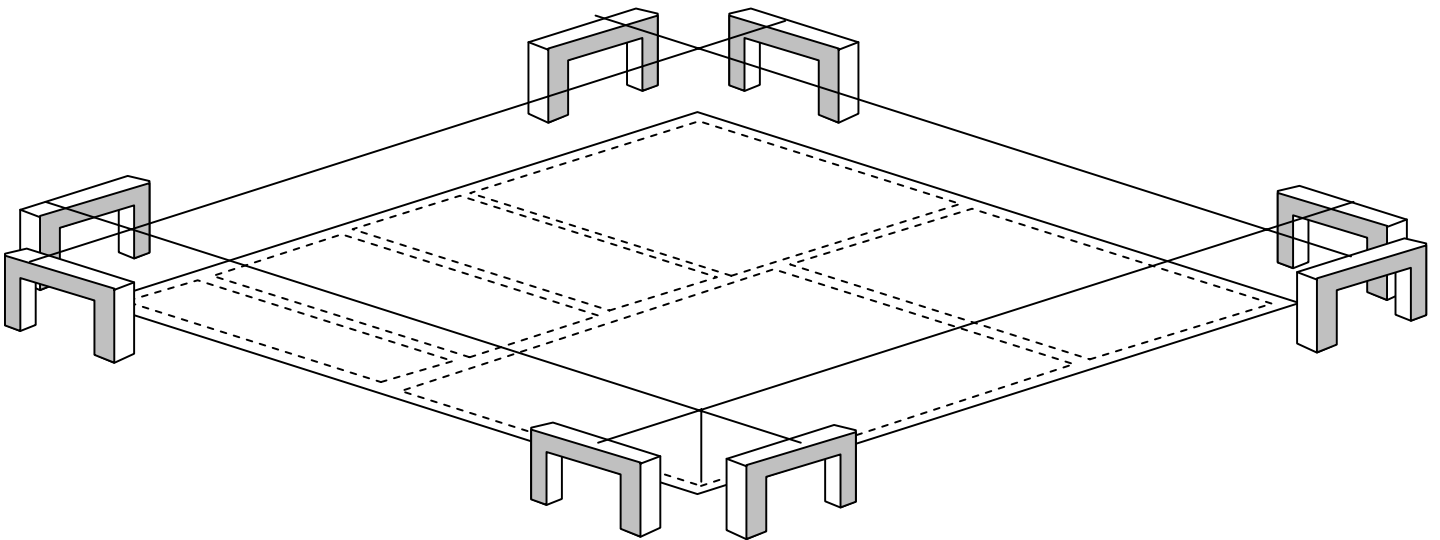

2. A 100 MM THICK CONSOLIDATED HARDCORE BED IS LAID BETWEEN THE STRIP FOOTING MARKS.

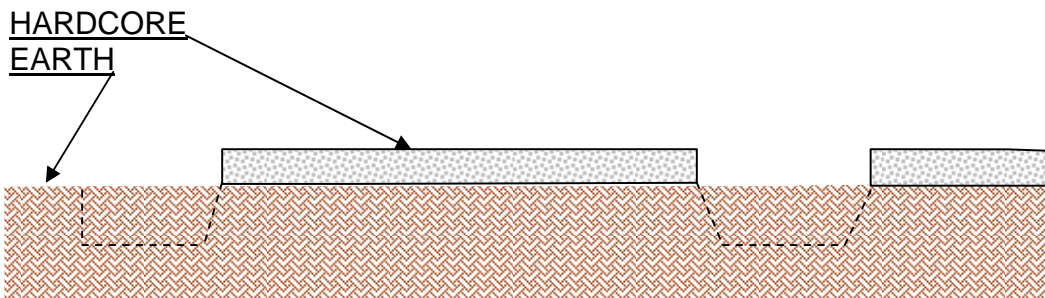

3. THE STRIP FOOTING IS EXCAVATED

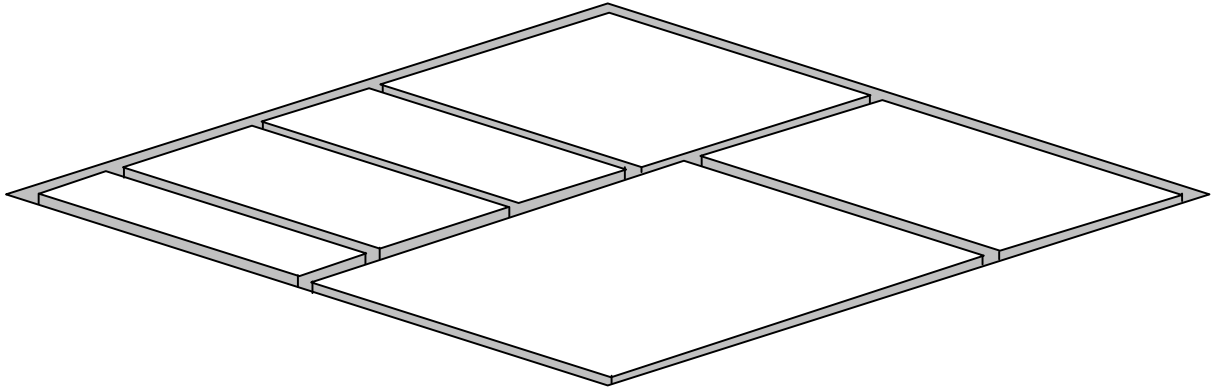

4. INSTALL UNDERGROUND PIPING AND DAMP PROOF MEMBRANE OVER THE hardcore BED.

5. POUR LEAN CONCRETE (GRADE 10) IN STRIP FOOTING, INSTALL SAWN FORMWORK AROUND THE CONCRETE FLOOR AREA AND INSTALL RE-ENFORCEMENT STEEL AND BRC-LAYER.

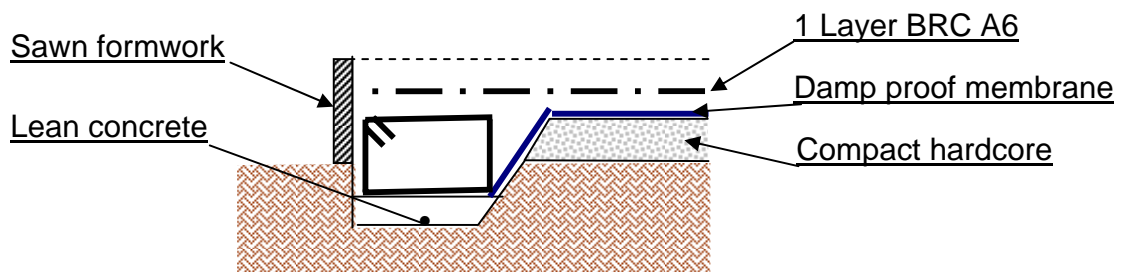

6. STARTER BARS ARE PLACED AT EACH POINT IN THE FLOOR WHERE AN RC COLUMN OR STIFFENER WILL CONNECT TO IT. CONCRETE (GRADE 20) IS POORED TO FORM THE RC FLOOR SLAB.

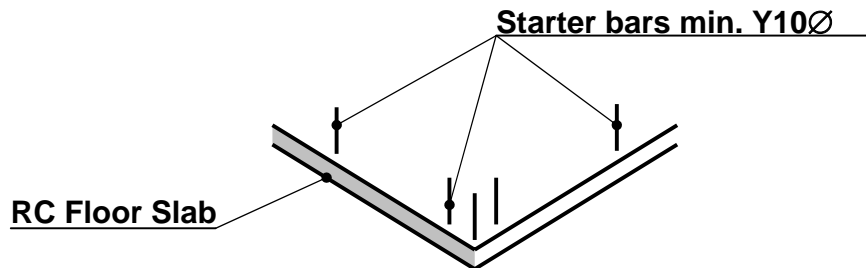

7. SETTING OUT AND INSTALLING FORMWORK (SINGLE FLAT FACE, HAVING A WIDTH OF WHICH IS 200 MM WIDER THAN THE WIDTH OF THE STIFFENER IT WILL FORM). THE FORMWORK IS ERECTED AND BRACED IN THE CORRECT POSITION ON THE RC FLOOR SLAB AT INTERVALS TO SUIT THE LENGTH OF THE WWCB PANELS. WWCB IS STACKED HORIZONTALLY AGAINST THE FORMWORK (A GAP OF 75 MM IS MAINTAINED BETWEEN THE ENDS OF EACH PANEL).

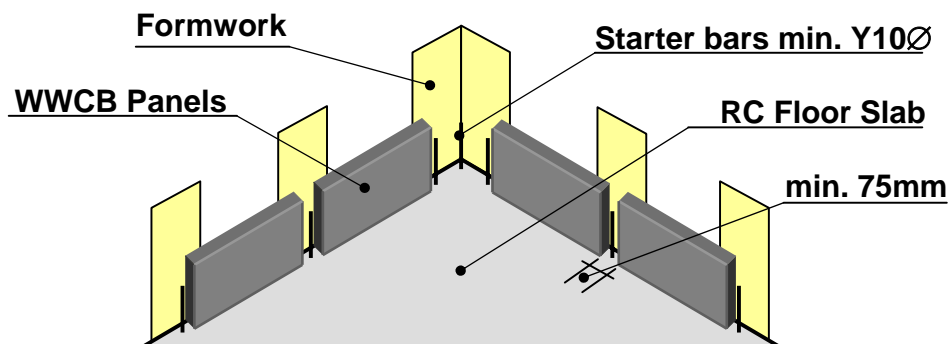

- 8. STACK THE WWCB UP TO RING BEAM HEIGHT AND INSTALL THE REINFORCING STEEL, TIED TO THE STARTER BARS. THE VOIDS ARE CLOSED WITH FORMWORK WHICH IS TIED THROUGH THE WWCB TO THE FORMWORK ON THE OPPOSITE SIDE AND THE VOIDS ARE FILLED WITH CONCRETE (GRADE 20) .**

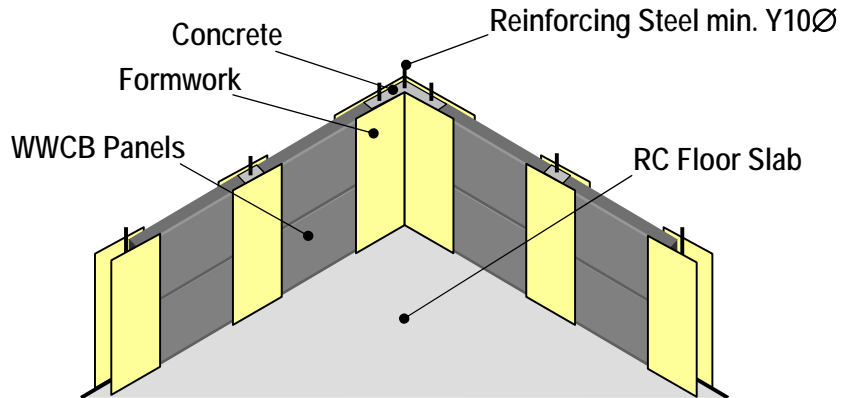

- 9. AFTER CURING, THE FORMWORK FOR THE RING BEAM IS INSTALLED, THE REINFORMENT STEEL PLACED AND TIED AND THE CONCRETE (GRADE 20) POURED.**

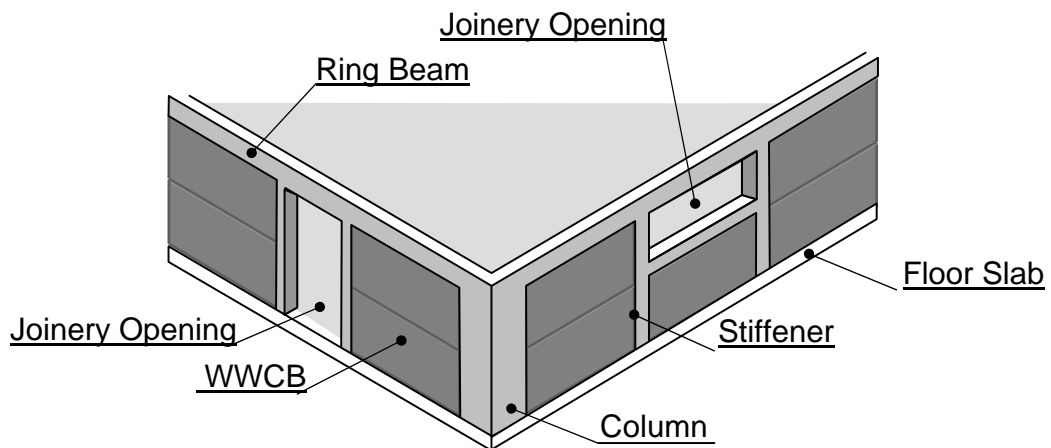

Note: Every joinery opening i.e. doors and windows lined with a 75mm x 75mm stiffening element.

10. THE ROOF (WOODEN OR METAL FRAME) IS INSTALLED ONTO THE WALL PLATE.



11. INSTALLING DURALITE AS ROOFING UNDERLAY

METHOD 1: It is of primary importance when installing DURALITE as roofing underlay that provision is made for adequate support. For this purpose DURALITE is normally laid out on purlins that spaced not more than $23 \frac{5}{8}$ " (600mm) center to center. The roof cladding will be fixed the DURALITE to the purlins. Sizalation can be laid out over the DURALITE.

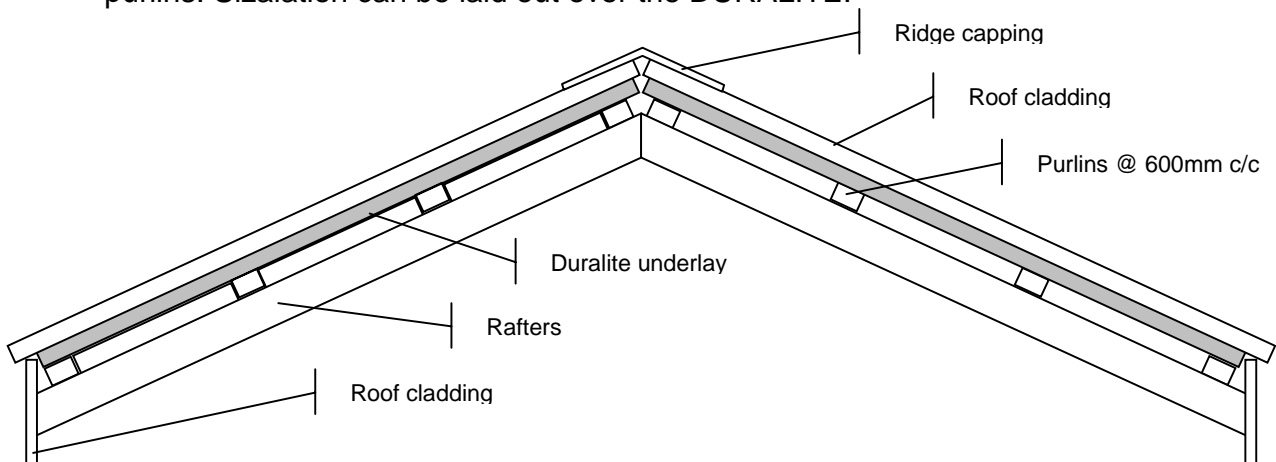

NOTE: Nails or screws fastening the roof cladding will need to be long enough to sufficiently penetrate the purlins through the roof cladding and DURALITE.

METHOD 2: DURALITE could be laid between the purlins and the rafters would be spaced at a maximum of $23\frac{5}{8}$ " (600mm) center to center. In this instance the purlins would need to be at least of the same thickness of the DURARITE or thicker.

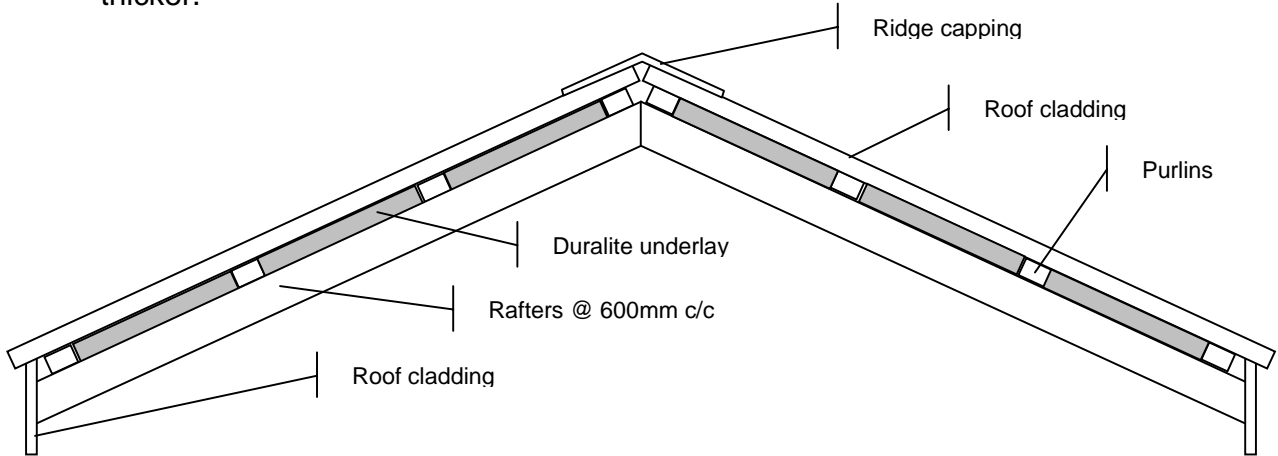

12. THE PIPING FOR WATER AND ELECTRICITY IS INSTALLED AND THE WALLS ARE PLASTERED WITH ONE 12MM THICK PLASTER LAYER.



13. AFTER THE PLASTER IS SUFFICIENTLY DRY THE HOUSE CAN BE PAINTED, AND ITS COMPLETE.

